

CONTENTS

Important User Information	2	Before You Begin	3
General	2	Required Tools	3
Manufacturer	2	Leveling the Cabinet	4
Intended Use	2	Securing the Cabinet(s) to the Wall	6
Warranty	2	Numbering System	7
		Changing Shelf Locations	8

Note: Please read and understand these instructions before assembling the parts.

Note: Remove all items from the shipping cartons and arrange them in a convenient location. Refer to the illustrations on the following pages. If you need additional information, contact Wenger Corporation using the information below.

IMPORTANT USER INFORMATION

GENERAL

Copyright © 2014 by Wenger Corporation

All rights reserved. No part of the contents of this manual may be reproduced, copied, or transmitted in any form or by any means including graphic, electronic, or mechanical methods or photocopying, recording, or information storage and retrieval systems without the written permission of the publisher, unless it is for the purchaser's personal use.

Printed and bound in the United States of America.

The information in this manual is subject to change without notice and does not represent a commitment on the part of Wenger Corporation. Wenger Corporation does not assume any responsibility for any errors that may appear in this manual.

In no event will Wenger Corporation be liable for technical or editorial omissions made herein, nor for direct, indirect, special, incidental, or consequential damages resulting from the use or defect of this manual.

The information in this document is not intended to cover all possible conditions and situations that might occur. The end user must exercise caution and common sense when assembling or installing Wenger Corporation products. If any questions or problems arise, call Wenger Corporation at 1-800-887-7145.

MANUFACTURER

The Tall Folio Cabinets are manufactured by:

Wenger Corporation
555 Park Drive
Owatonna, MN 55060
1-800-4WENGER (493-6437) • 1-507-455-4100
www.wengercorp.com

INTENDED USE

- This product is intended for indoor use in normal ambient temperature and humidity conditions — it must not be exposed to prolonged outside weather conditions.
- This product is intended to be assembled and used only as described in these instructions.

WARRANTY

These products are guaranteed free of defects in materials and workmanship for five full years from date of shipment. A full warranty statement is available upon request.

BEFORE YOU BEGIN

- The Tall Folio Cabinet is shipped almost entirely assembled. To install, level the unit and attach the few remaining components as outlined in these instructions.
- Read the complete assembly procedure before you begin.
- Remove all items from the shipping carton, and lay them out approximately in their final position.

REQUIRED TOOLS

The following tools must be available to assemble the Tall Folio Cabinets:

- Carpenter's Level
- Carpenter's Square
- Plastic Mallet
- Variable Speed Drill (to drive hex socket screws)
- 4mm Hex Drive for Drill.

LEVELING THE CABINET

NOTE: Do Not try to level the cabinet to match soffits.
Do Not try to plumb the cabinet to match adjacent walls.
Do Not install door handles until cabinets have been leveled. For proper door alignment, follow these instructions carefully.
See "Changing Shelf Locations" for removal of file drawers prior to leveling cabinet.

1. Check the level of the entire floor where the cabinets will be installed. Determine the highest point of the floor in that area. Extend all levelers until the bottom of the cabinet will be higher than the highest point in the floor.

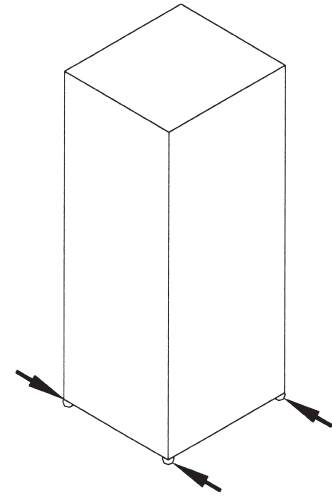

2. Adjust the levelers on one side until the front edges of the cabinet side panels are plumb (side-to-side).

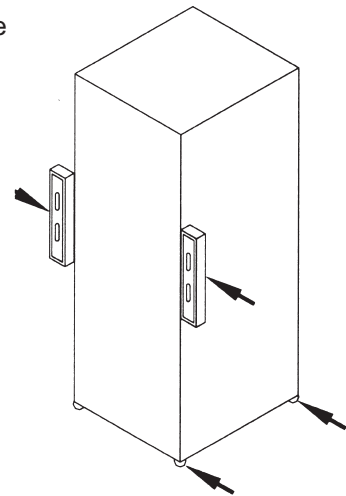

LEVELING THE CABINET (CONTINUED)

3. Measure A and B with a tape and adjust the front levelers until $A=B$ (+ 1/32 inch).

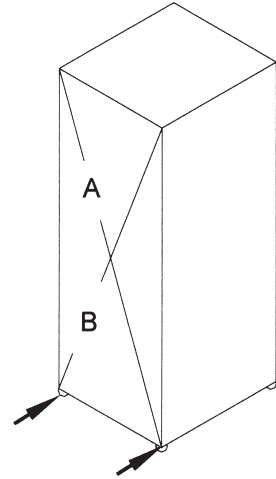

4. Adjust both front levelers equally until the front edges of the cabinet are plumb (front-to-back).

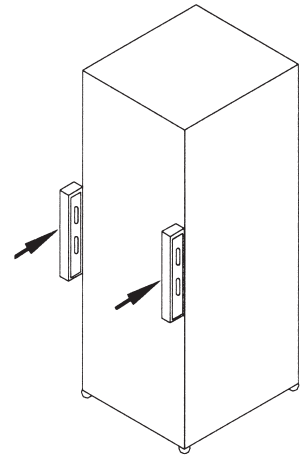

5. Recheck that $A=B$ and that the door is even with the top panel. Readjust if necessary (steps 2 - 4). Insert hole plugs into the two holes that are in the bottom shelf for leveling the cabinet.

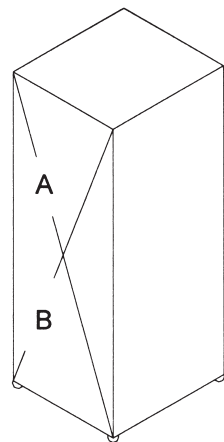

SECURING THE CABINET(S) TO THE WALL

There are L-shaped brackets in the hardware bag for attaching the cabinets to your wall surface. Because of the variety of possible wall surfaces, fasteners are not included. Have your maintenance people recommend an appropriate type for safe, secure attachment.

NOTE: Make sure all the cabinets are secured together before you attach them to the back wall.

1. Using the L-shaped brackets, you can tie cabinets together and to the wall surface at the top. The brackets have extra holes: if the cabinets can't be positioned tight against the wall, you can slide the bracket back as much as 2" until it is tight against the wall surface.
2. Use the necessary fasteners suggested by your maintenance people to secure the cabinets to the wall.

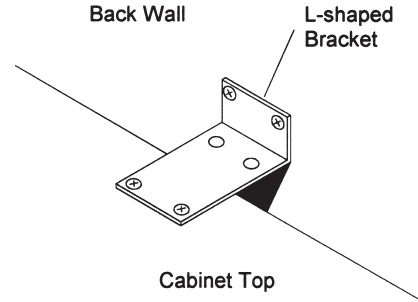

⚠ CAUTION
<i>Cabinets must be properly secured to the back wall and are unsafe if not properly secured as specified.</i>

⚠ CAUTION
<i>Use methods appropriate to your wall surfaces.</i>

⚠ CAUTION
<i>Do not walk or load anything on top of Folio Cabinets.</i>

NUMBERING SYSTEM

1. To assign numbers to individual slots, use enclosed number strips or blank strips. They can be added or removed in the black extrusions as your numbering system changes. Refer to Step 1 under “Changing Shelf Locations” to remove extrusions. Letters or numbers can be written on the strips using ink pen, marking pen or permanent markers and can be easily erased with all purpose cleaner (or industrial cleaner for dry erase markers) or slide the pre-printed enclosed number strip into the slot as shown.

Note: At the top of each number strip, the shelf spacing is identified.

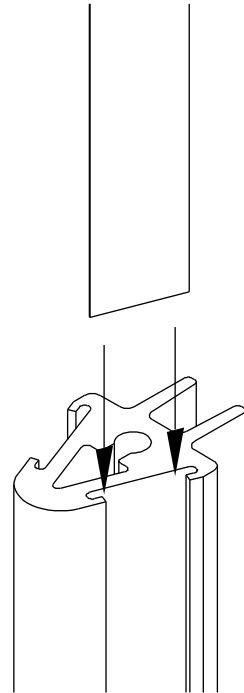

CHANGING SHELF LOCATIONS

A Philips Head Screwdriver is required to change the shelf locations.

1. Wenger Mobile Folio Cabinets are shipped with the shelves already installed. They are held in place by an aluminum extrusion which runs from top to bottom of each compartment.

To change shelf locations, follow these instructions to remove as many of the stops as necessary. After moving the shelves, reinstall the extrusions.

2. To remove the extrusions in the middle of the cabinet, remove the two screws at the top of each extrusion, pull the top of the extrusion forward, and lift the extrusion along with the plastic bracket out of the lower bracket.

Reposition shelves in the appropriate slots prior to replacing the extrusions.

